

HARTING



Han-Power®

Power Network Solution

General information

Fields of application

HARTING Industrial Connectors are applicable in a wide variety of electronic and electrical applications.

The degree of protection of all hoods and housings is in accordance with International Standard IEC 60 529.

- Power Utilities
- Robotics
- Chemical Plants
- Machine Tool Controls
- Injection Moulding
- Industrial Instrumentation
- Conveyor Equipment
- Transportation
- and many more.

Specifications

VDE 0110 table concerning clearance and creepage distances

VDE 0627 Connectors and plug devices

Standards: DIN EN 175 301 - 801
DIN EN 61 984

Approvals

UL, CSA for inserts

Note

Connectors should not be coupled and decoupled under electrical load. Connectors of the same or different series being mounted side by side may be protected against incorrect mating by the use of coding options.

General information

It is the user's responsibility to check whether the components illustrated in this catalogue comply with different regulations from those stated in special fields of application which we are unable to foresee.

We reserve the right to modify designs in order to improve quality, keep pace with technological advancement or meet particular requirements in production.

No part of this catalogue may be reproduced in any form (print, photocopy, microfilm or any other process) or processed, duplicated or distributed by means of electronic systems without the prior written consent of HARTING Electric GmbH & Co. KG, Espelkamp. We are bound by the German version only.



Certified according to EN ISO 9001
in design/development, production,
installation and servicing





HARTING Power Network products have been applied in the project “High Rack and Commission Stock” at company RILA delicatessen import in Stemwede-Levern, Germany.

The decentralized motor control units are provided with energy by a power bus system in bus topology instead of a star configured power system. Reasons for this were on the one hand to save cabling and installation time and on the other to take into account future potential savings in maintenance costs.

Due to the low construction height of the applied Han-Power® S products they could be positioned within the cable duct. Therefore the

cable conduit did not have to be fed out in a complex way. The decentralised components are directly connected on the cable duct side, which leads to savings especially in time-critical maintenance work. In addition the Han-Power® S variant features two connector branches. This is advantageous especially where two drives of rack conveyor systems are often very close to one another. So with this dual variant two adjacent drives can be connected to one branch. The cable conduit has been realized with 2.5 mm² cabling. The branches connecting to the motor control units use 1.5 mm² cabling, taking a maximum of 3 meters length into account.

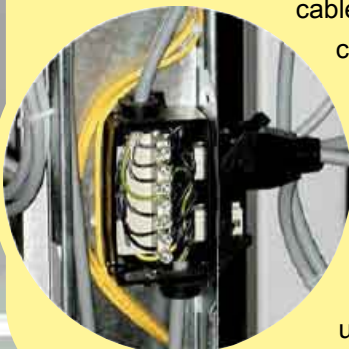



The construction and installation of logistic centre



systems can be simplified and economically achieved by the inclusion of Han-Power® T electric supply distribution products. Fast installation and commissioning of modular conveyor belts is guaranteed when modern design concepts are considered and pre-assembled cable systems are utilised.

The pictures show the HARTING logistic centre in Espelkamp.



General information

BUS Topology for Power Transfer

Machine and facility developers are advancing the implementation of device function decentralization with standardized interfaces. The objective is to integrate cost-optimized installation technology for power distribution and consequently to revolutionize and optimize installation technology that has developed over the course of many years.

Conventional wiring is characterized by the point-to-point installation of the signal and power transfers. In practice, this means that each motor is connected to a power cable from the control cabinet. All sensor and actuator terminals, such as for proximity switches or valves, are also wired in parallel.

The introduction of serial bus components for connecting sensors and actuators marked a key step in technical progress in the circuitry area.

The HARTING Technology Group is supporting this change in installation engineering.

An essential element in this new wiring technology is a power bus system that allows a number of “consumers” to be connected on one cabling line, while still complying with all relevant national and international standards.

This innovation must fall back on existing and standardized interfaces

In principle, it is possible to distinguish two connection types in this installation concept

Power bus distribution with Han-Power® S
on an uncut cabling line, where the individual wires are tapped.

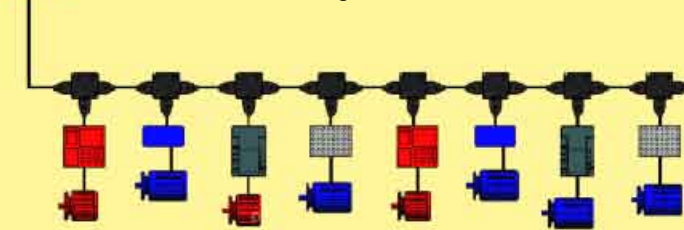

Power branch is completely pluggable with Han-Power® T,
in order to provide a quick and time-saving electrical connection for
machine and facility modules.

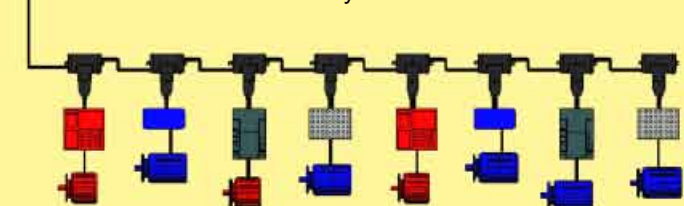

Features

- 6 IDCs + PE for 2.5 mm² up to 6 mm² wire gauge
- No interruption of the energy supply
- Space-saving and compact design
- Leading protective ground within the insert
- Assembly with standard tools

Description

The Han-Power® S connector is suitable for the assembly of serial power bus. Having assembled the energy supply Han-Power® S can be inserted at any place of the power cable. The cable mantle has to be removed, the conductor is placed without interruption in the IDC. Han-Power® S is suitable for cables with single strands manufactured acc. to DIN VDE 0281/ DIN VDE 0295 with wire gauges of 2.5 mm² up to 6 mm². For the distribution of the device Han-Compact® hoods or cable to cable housings are used. The power supply has to be realized with one Han-Compact® cable to cable hood.

Derating diagram

The power rating of the connectors is limited by the thermal load capability of the contact element material including the connections and the insulating parts. The derating curve is therefore valid for currents which flow constantly (non-intermittent) through each contact element of the connector evenly, without exceeding the allowed maximum temperature.

Measuring and testing techniques according to DIN EN 60 512-5

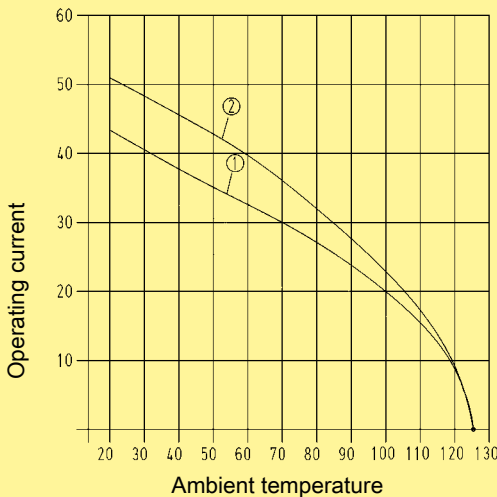

① Han® Q 4/2 Wire gauge: 4 mm²

② Han® Q 4/2 Wire gauge: 6 mm²

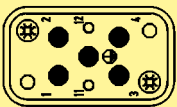

Han® Q 4/2 fully loaded with wire gauge 4x 6 mm²

Technical characteristics

| | |
|----------------|-------------------------------|
| Specifications | DIN EN 61 984 DIN VDE 0110 |
|----------------|-------------------------------|

Han-Power® S

| | |
|--|------------------------------|
| Number of contacts | |
| - Power contacts | 4 + PE |
| - Signal contacts | 2 |
| Electrical data | |
| acc. to EN 61 984 | 40 A 400/690 V 6 kV 3 |
| Rated current | 40 A |
| Rated voltage conductor - ground | 400 V |
| Rated voltage conductor - conductor | 690 V |
| Rated impulse voltage | 6 kV |
| Pollution degree | 3 |
| Rated voltage acc. to UL/CSA | 600 V |
| Material | Polycarbonate |
| Insulation resistance | ≥ 10 ¹⁰ kΩ |
| Limiting temperatures | -40 °C ... 125 °C |
| Flammability acc. to UL 94 | V 0 |
| Degree of protection acc. to EN 60 529 | IP 65 |

Contacts Han® C

| | |
|---|-------------------------|
| Material | copper alloy |
| Surface | |
| - hard-silver plated | 5 μm Ag |
| Contact resistance | ≤ 0.3 mΩ |
| Crimp terminal | |
| - mm ² | 2.5 - 6 mm ² |
| - AWG | AWG 14 - 10 |
| Max. insulation diameter of single strand | 5 mm |

Hoods/housings Han-Compact®

| | |
|--|---------------------------|
| Material | Polycarbonate RAL 9005 |
| Hoods/Housings sealing | NBR |
| Temperature range | |
| - Connecting temperature | -25 °C ... 40 °C |
| - Working temperature | -25 °C ... 80 °C |
| Flammability acc. to UL 94 | V 0 |
| Degree of protection acc. to EN 60 529 for coupled connector | IP 65 |

cable

| | |
|-----------------------------|----------------------------------|
| Design of conductor acc. to | • DIN VDE 0281 • DIN VDE 0295 |
|-----------------------------|----------------------------------|

Single strand

| | |
|--------------------------------|----------------|
| Wire gauge 2.5 mm ² | |
| - Number of single strands | 50 x 0.25 mm ∅ |
| - Outer diameter | 3.6 mm ∅ |
| Wire gauge 4 mm ² | |
| - Number of single strands | 56 x 0.3 mm ∅ |
| - Outer diameter | 4.2 mm ∅ |



with 1x Han® Q 4/2

| Identification | Part number | Drawing | Dimensions in mm |
|---|-------------------------|-----------------------|------------------|
| Han-Power® S Power supply Han® Q 4/2; 1 moulded Han-Compact® Hoods | 2.5 - 4 mm ² | 09 12 008 4804 | |
| | 4 - 6 mm ² | 09 12 008 4806 | |
| | | | |

| Identification | Part number | Drawing | Dimensions in mm |
|--|---------------------------------|--|------------------|
| System cables in fixed lengths Cable lengths (total length) in m pre-assembled on both sides plastic hood, black top entry cable to cable hood with male insert and hood with female insert cable: 5x 4 mm ² | 1.5 3 5 10 15 30 | 20 88 641 1015 20 88 641 1030 20 88 641 1050 20 88 641 1100 20 88 641 1150 20 88 641 1300 | |

Features

- 6 IDCs + PE for 2.5 mm² up to 6 mm² wire gauge
- No interruption of the energy supply
- Space-saving and compact design
- Leading protective ground within the insert
- Assembly with standard tools

Description

The Han-Power® S connector is suitable for the assembly of serial power bus. Having assembled the energy supply Han-Power® S can be inserted at any place of the power cable. The cable mantle has to be removed, the conductor is placed without interruption in the IDC. Han-Power® S is suitable for cables with single strands manufactured acc. to DIN VDE 0281/ DIN VDE 0295 with wire gauges of 2.5 mm² up to 6 mm². For the distribution of the device Han-Compact® hoods or cable to cable housings are used. The power supply has to be realized with one Han-Compact® cable to cable hood.

Derating diagram

The power rating of the connectors is limited by the thermal load capability of the contact element material including the connections and the insulating parts. The derating curve is therefore valid for currents which flow constantly (non-intermittent) through each contact element of the connector evenly, without exceeding the allowed maximum temperature.

Measuring and testing techniques according to DIN EN 60 512-5

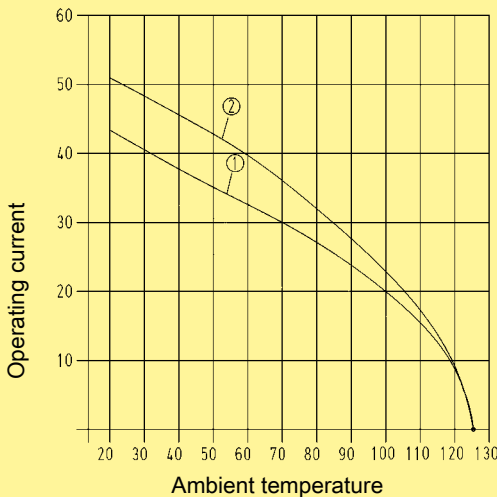

① Han® Q 4/2 Wire gauge: 4 mm²

② Han® Q 4/2 Wire gauge: 6 mm²

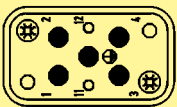

Han® Q 4/2 fully loaded with wire gauge 4x 6 mm²

Technical characteristics

| | |
|----------------|-------------------------------|
| Specifications | DIN EN 61 984 DIN VDE 0110 |
|----------------|-------------------------------|

Han-Power® S

| | |
|--|-------------------------------|
| Number of contacts | |
| - Power contacts | 4 + PE |
| - Signal contacts | 2 |
| Electrical data | |
| acc. to EN 61 984 | 40 A 400/690 kV 6 kV 3 |
| Rated current | 40 A |
| Rated voltage conductor - ground | 400 V |
| Rated voltage conductor - conductor | 690 kV |
| Rated impulse voltage | 6 kV |
| Pollution degree | 3 |
| Rated voltage acc. to UL/CSA | 600 V |
| Material | Polycarbonate |
| Insulation resistance | ≥ 10 ¹⁰ kΩ |
| Limiting temperatures | -40 °C ... 125 °C |
| Flammability acc. to UL 94 | V 0 |
| Degree of protection acc. to EN 60 529 | IP 65 |

Contacts Han® C

| | |
|---|-----------------------|
| Material | copper alloy |
| Surface | |
| - hard-silver plated | 5 μm Ag |
| Contact resistance | ≤ 0.3 mΩ |
| Crimp terminal | |
| - mm ² | 4 - 6 mm ² |
| - AWG | AWG 14 - 10 |
| Max. insulation diameter of single strand | 5 mm |

Hoods/housings Han-Compact®

| | |
|--|---------------------------|
| Material | Polycarbonate RAL 9005 |
| Hoods/Housings sealing | NBR |
| Temperature range | |
| - Connecting temperature | -25 °C ... 40 °C |
| - Working temperature | -25 °C ... 80 °C |
| Flammability acc. to UL 94 | V 0 |
| Degree of protection acc. to EN 60 529 for coupled connector | IP 65 |

cable

| | |
|-----------------------------|----------------------------------|
| Design of conductor acc. to | • DIN VDE 0281 • DIN VDE 0295 |
|-----------------------------|----------------------------------|

Single strand

| | |
|--------------------------------|----------------|
| Wire gauge 2.5 mm ² | |
| - Number of single strands | 50 x 0.25 mm Ø |
| - Outer diameter | 3.6 mm Ø |
| Wire gauge 4 mm ² | |
| - Number of single strands | 56 x 0.3 mm Ø |
| - Outer diameter | 4.2 mm Ø |



with 2x Han® Q 4/2

| Identification | Part number | Drawing | Dimensions in mm |
|--|--|---------|------------------|
| <p>Han-Power® S</p> <p>Power supply</p> <p>Han® Q 4/2; 2 screwed</p> <p>Han-Compact® Housings, bulkhead mounting</p> | <p>4 - 6 mm²</p> <p>09 12 008 4807</p> | | |

| Identification | Part number | Drawing | Dimensions in mm |
|--|--|---------|------------------|
| <p>System cables in fixed lengths</p> <p>Cable lengths (total length) in m</p> <p>pre-assembled on both sides</p> <p>plastic hood, black</p> <p>top entry</p> <p>cable to cable hood with male insert</p> <p>and hood with female insert</p> <p>cable: 5x 4 mm²</p> | <p>1.5</p> <p>3</p> <p>5</p> <p>10</p> <p>15</p> <p>30</p> <p>20 88 641 1015</p> <p>20 88 641 1030</p> <p>20 88 641 1050</p> <p>20 88 641 1100</p> <p>20 88 641 1150</p> <p>20 88 641 1300</p> | | |

Features

- 6 IDCs + PE for 2.5 mm² up to 6 mm² wire gauge
- No interruption of the energy supply
- Space-saving and compact design
- Leading protective ground within the insert
- Assembly with standard tools

Description

The Han-Power® S connector is suitable for the assembly of serial power bus. Having assembled the energy supply Han-Power® S can be inserted at any place of the power cable. The cable mantle has to be removed, the conductor is placed without interruption in the IDC. Han-Power® S is suitable for cables with single strands manufactured acc. to DIN VDE 0281/ DIN VDE 0295 with wire gauges of 2.5 mm² up to 6 mm². For the distribution of the device Han-Compact® hoods or cable to cable housings are used. The power supply has to be realized with one Han-Compact® cable to cable hood.

Derating diagram

The power rating of the connectors is limited by the thermal load capability of the contact element material including the connections and the insulating parts. The derating curve is therefore valid for currents which flow constantly (non-intermittent) through each contact element of the connector evenly, without exceeding the allowed maximum temperature.

Measuring and testing techniques according to DIN EN 60 512-5

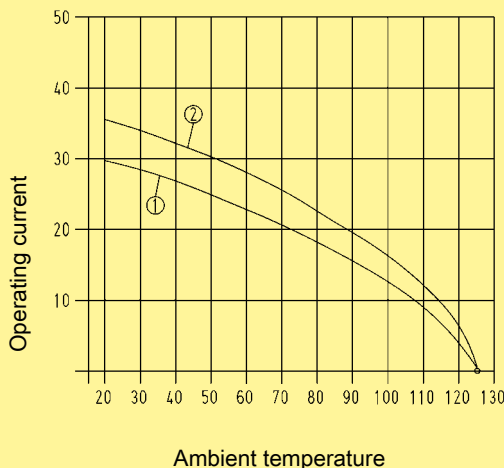

① Han® Q 8/0 Wire gauge: 2.5 mm²

② Han® Q 8/0 Wire gauge: 4 mm²

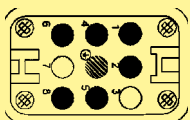

Han® Q 8/0 partly loaded with wire gauge 7x 4 mm²

Technical characteristics

| | |
|----------------|-------------------------------|
| Specifications | DIN EN 61 984 DIN VDE 0110 |
|----------------|-------------------------------|

Han-Power® S

| | |
|--|--------------------------|
| Number of contacts | |
| - Power contacts | 6 + PE |
| Electrical data acc. to EN 61 984 | 25 A 500 V 6 kV 3 |
| Rated current | 25 A |
| Rated voltage | 500 V |
| Rated impulse voltage | 6 kV |
| Pollution degree | 3 |
| Rated voltage acc. to UL/CSA | 600 V |
| Material | Polycarbonate |
| Insulation resistance | ≥ 10 ¹⁰ kΩ |
| Limiting temperatures | -40 °C ... 125 °C |
| Flammability acc. to UL 94 | V 0 |
| Degree of protection acc. to EN 60 529 | IP 65 |

Contacts Han E®

| | |
|----------------------|-------------------------|
| Material | copper alloy |
| Surface | |
| - hard-silver plated | 3 μm Ag |
| Contact resistance | ≤ 1 mΩ |
| Crimp terminal | |
| - mm ² | 2.5 - 4 mm ² |
| - AWG | AWG 14 - 12 |

Hoods/housings Han-Compact®

| | |
|--|---------------------------|
| Material | Polycarbonate RAL 9005 |
| Hoods/Housings sealing | NBR |
| Temperature range | |
| - Connecting temperature | -25 °C ... 40 °C |
| - Working temperature | -25 °C ... 80 °C |
| Flammability acc. to UL 94 | V 0 |
| Degree of protection acc. to EN 60 529 for coupled connector | IP 65 |

cable

| | |
|-----------------------------|----------------------------------|
| Design of conductor acc. to | • DIN VDE 0281 • DIN VDE 0295 |
|-----------------------------|----------------------------------|

Single strand

| | |
|--------------------------------|----------------|
| Wire gauge 2.5 mm ² | |
| - Number of single strands | 50 x 0.25 mm Ø |
| - Outer diameter | 3.6 mm Ø |
| Wire gauge 4 mm ² | |
| - Number of single strands | 56 x 0.3 mm Ø |
| - Outer diameter | 4.2 mm Ø |



with 1x Han® Q 8/0

| Identification | Part number | Drawing | Dimensions in mm |
|--|-----------------------|---------|------------------|
| <p>Han-Power® S</p> <p>Power supply</p> <p>Han® Q 8/0; 1 moulded</p> <p>Han-Compact® Hoods</p> | | | |
| 2.5 - 4 mm ² | 09 12 008 4801 | | |
| 4 - 6 mm ² | 09 12 008 4811 | | |

| Identification | Part number | Drawing | Dimensions in mm |
|--|-----------------------|---------|------------------|
| <p>System cables in fixed lengths</p> <p>Cable lengths (total length) in m</p> <p>pre-assembled on both sides</p> <p>plastic hood, black</p> <p>top entry</p> <p>cable to cable hood with male insert</p> <p>and hood with female insert</p> <p>cable: 7x 2.5 mm²</p> | | | |
| 1.5 | 20 88 841 0015 | | |
| 3 | 20 88 841 0030 | | |
| 5 | 20 88 841 0050 | | |
| 10 | 20 88 841 0100 | | |
| 15 | 20 88 841 0150 | | |
| 30 | 20 88 841 0300 | | |

Features

- 6 IDCs + PE for 2.5 mm² up to 6 mm² wire gauge
- No interruption of the energy supply
- Space-saving and compact design
- Leading protective ground within the insert
- Assembly with standard tools

Description

The Han-Power® S connector is suitable for the assembly of serial power bus. Having assembled the energy supply Han-Power® S can be inserted at any place of the power cable. The cable mantle has to be removed, the conductor is placed without interruption in the IDC. Han-Power® S is suitable for cables with single strands manufactured acc. to DIN VDE 0281/ DIN VDE 0295 with wire gauges of 2.5 mm² up to 6 mm². For the distribution of the device Han-Compact® hoods or cable to cable housings are used. The power supply has to be realized with two Han-Compact® hoods.

Derating diagram

The power rating of the connectors is limited by the thermal load capability of the contact element material including the connections and the insulating parts. The derating curve is therefore valid for currents which flow constantly (non-intermittent) through each contact element of the connector evenly, without exceeding the allowed maximum temperature.

Measuring and testing techniques according to DIN EN 60 512-5

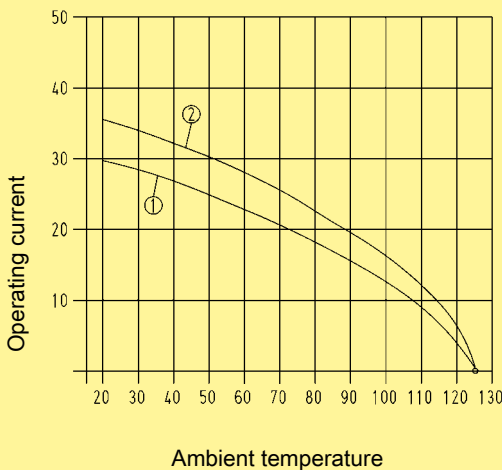

① Han® Q 8/0 Wire gauge: 2.5 mm²

② Han® Q 8/0 Wire gauge: 4 mm²

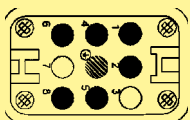

Han® Q 8/0 partly loaded with wire gauge 7x 4 mm²

Technical characteristics

| | |
|----------------|-------------------------------|
| Specifications | DIN EN 61 984 DIN VDE 0110 |
|----------------|-------------------------------|

Han-Power® S

| | |
|--|--------------------------|
| Number of contacts | |
| - Power contacts | 6 + PE |
| Electrical data | |
| acc. to EN 61 984 | 25 A 500 V 6 kV 3 |
| Rated current | 25 A |
| Rated voltage | 500 V |
| Rated impulse voltage | 6 kV |
| Pollution degree | 3 |
| Rated voltage | |
| acc. to UL/CSA | 600 V |
| Material | Polycarbonate |
| Insulation resistance | ≥ 10 ¹⁰ kΩ |
| Limiting temperatures | -40 °C ... 125 °C |
| Flammability acc. to UL 94 | V 0 |
| Degree of protection acc. to EN 60 529 | IP 65 |

Contacts Han E®

| | |
|----------------------|-------------------------|
| Material | copper alloy |
| Surface | |
| - hard-silver plated | 3 μm Ag |
| Contact resistance | ≤ 1 mΩ |
| Crimp terminal | |
| - mm ² | 2.5 - 4 mm ² |
| - AWG | AWG 14 - 12 |

Hoods/housings Han-Compact®

| | |
|--|------------------|
| Material | Polycarbonate |
| | RAL 9005 |
| Hoods/Housings sealing | NBR |
| Temperature range | |
| - Connecting temperature | -25 °C ... 40 °C |
| - Working temperature | -25 °C ... 80 °C |
| Flammability acc. to UL 94 | V 0 |
| Degree of protection acc. to EN 60 529 | |
| for coupled connector | IP 65 |

cable

| | |
|-----------------------------|----------------------------------|
| Design of conductor acc. to | • DIN VDE 0281 • DIN VDE 0295 |
|-----------------------------|----------------------------------|

Single strand

| | |
|--------------------------------|----------------|
| Wire gauge 2.5 mm ² | |
| - Number of single strands | 50 x 0.25 mm Ø |
| - Outer diameter | 3.6 mm Ø |
| Wire gauge 4 mm ² | |
| - Number of single strands | 56 x 0.3 mm Ø |
| - Outer diameter | 4.2 mm Ø |



with 2x Han® Q 8/0

| Identification | Part number | Drawing | Dimensions in mm |
|---|-----------------------|---------|------------------|
| <p>Han-Power® S</p> <p>Power supply</p> <p>Han® Q 8/0; 2 screwed</p> <p>Han-Compact® Housings, bulkhead mounting</p> <p>2.5 - 4 mm²</p> | 09 12 008 4802 | | |

| Identification | Part number | Drawing | Dimensions in mm |
|--|--|---------|------------------|
| <p>System cables in fixed lengths</p> <p>Cable lengths (total length) in m</p> <p>pre-assembled on both sides</p> <p>plastic hood, black</p> <p>top entry</p> <p>hood on both sides</p> <p>cable: 7x 2.5 mm²</p> | <p>1.5 20 88 821 0015</p> <p>3 20 88 821 0030</p> <p>5 20 88 821 0050</p> <p>10 20 88 821 0100</p> <p>15 20 88 821 0150</p> <p>30 20 88 821 0300</p> | | |

Features

- 6 IDCs/screw terminals + PE for 2.5 mm² up to 6 mm² wire gauge; 4 IDCs + PE for 10 mm² wire gauge
- No interruption of the energy supply
- Space-saving and compact design
- Leading protective ground within the insert
- Assembly with standard tools

Description

Han-Power® S metal version allows the realisation of applications where a high degree of protection is required against dust, splashed water and mechanical shock. This new variant continues to support the user in providing simple installation and maintenance practices but now offers greater protection against harsh industrial environments.

Han-Power® S metal offers optimal handling characteristics and now features an increased wire gauge range. It is now possible to realise power distribution networks with wire gauge up to 10 mm².

The power supply has to be realized with one Han-Compact® cable to cable hood.

Derating diagram

The power rating of the connectors is limited by the thermal load capability of the contact element material including the connections and the insulating parts. The derating curve is therefore valid for currents which flow constantly (non-intermittent) through each contact element of the connector evenly, without exceeding the allowed maximum temperature.

Measuring and testing techniques according to DIN EN 60 512-5

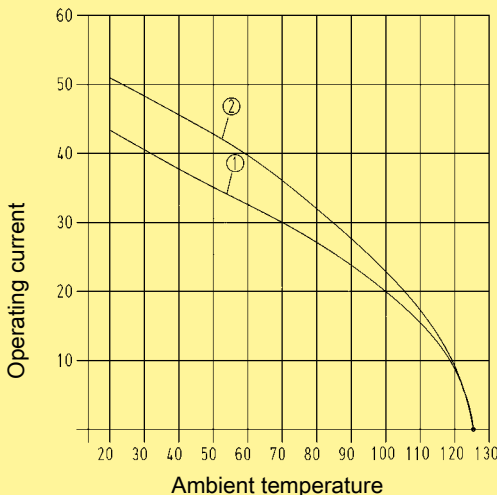

① Han® Q 4/2 Wire gauge: 4 mm²

② Han® Q 4/2 Wire gauge: 6 mm²

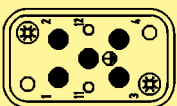

Han® Q 4/2 fully loaded with wire gauge 4x 6 mm²

Technical characteristics

| | |
|----------------|-------------------------------|
| Specifications | DIN EN 61 984 DIN VDE 0110 |
|----------------|-------------------------------|

Han-Power® S

| | |
|--|------------------------------|
| Number of contacts | |
| - Power contacts | 4 + PE |
| - Signal contacts | 2 |
| Electrical data acc. to EN 61 984 | 40 A 400/690 V 6 kV 3 |
| Rated current | 40 A |
| Rated voltage conductor - ground | 400 V |
| Rated voltage conductor - conductor | 690 V |
| Rated impulse voltage | 6 kV |
| Pollution degree | 3 |
| Rated voltage acc. to UL/CSA | 600 V |
| Material | aluminium die-cast |
| Insulation resistance | ≥ 10 ¹⁰ kΩ |
| Limiting temperatures | -40 °C ... 125 °C |
| Flammability acc. to UL 94 | V 0 |
| Degree of protection acc. to EN 60 529 | IP 65 |

Contacts Han® C

| | |
|----------------------|------------------------|
| Material | copper alloy |
| Surface | |
| - hard-silver plated | 5 µm Ag |
| Contact resistance | ≤ 0.3 mΩ |
| Crimp terminal | |
| - mm ² | 4 - 10 mm ² |
| - AWG | AWG 12 - 8 |

Hoods/housings Han-Compact®

| | |
|--|---------------------------|
| Material | zinc die-cast RAL 9005 |
| Hoods/Housings sealing | NBR |
| Limiting temperature range | -40 °C ... 125 °C |
| Degree of protection acc. to EN 60 529 for coupled connector | IP 65 |

cable

| | |
|-----------------------------|----------------------------------|
| Design of conductor acc. to | • DIN VDE 0281 • DIN VDE 0295 |
|-----------------------------|----------------------------------|

Single strand

| | |
|--------------------------------|----------------|
| Wire gauge 2.5 mm ² | |
| - Number of single strands | 50 x 0.25 mm Ø |
| - Outer diameter | 3.6 mm Ø |
| Wire gauge 4 mm ² | |
| - Number of single strands | 56 x 0.3 mm Ø |
| - Outer diameter | 4.2 mm Ø |



with 1x Han® Q 4/2, metal

| Identification | Part number | Drawing | Dimensions in mm |
|--|------------------------------|---------|------------------|
| <p>Han-Power® S</p> <p>Power supply</p> <p>Han® Q 4/2; 1 moulded</p> <p>Han-Compact® Housings, bulkhead mounting</p> <p>4 - 6 mm²</p> | <p>09 12 008 4901</p> | | |
| <p>10 mm²</p> | <p>09 12 008 4951</p> | | |

Features

- Per 1 connection for power input, power output and to device
- Male and female inserts finger protected
- 4 power contacts; 2 signal contacts
- Metal housing
- Locking lever stainless steel

Derating diagram

The power rating of the connectors is limited by the thermal load capability of the contact element material including the connections and the insulating parts. The derating curve is therefore valid for currents which flow constantly (non-intermittent) through each contact element of the connector evenly, without exceeding the allowed maximum temperature.

Measuring and testing techniques according to DIN EN 60 512-5

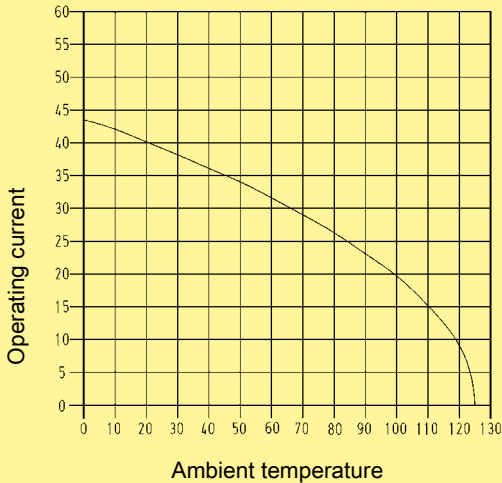

Wire gauge: 4 mm²

Technical characteristics

| | |
|----------------|-------------------------------|
| Specifications | DIN EN 61 984 DIN VDE 0110 |
|----------------|-------------------------------|

Han-Power® T

| | |
|--------------------|------------------------------|
| Number of contacts | |
| - Power contacts | 4 + PE / ≤ 6 mm ² |
| - Signal contacts | 2 / ≤ 2.5 mm ² |

| | |
|-------------------------------------|------------------------------|
| Electrical data | |
| acc. to EN 61 984 | 40 A 400/690 V 6 kV 3 |
| Rated current | 40 A |
| Rated voltage conductor - ground | 400 V |
| Rated voltage conductor - conductor | 690 V |
| Rated impulse voltage | 6 kV |
| Pollution degree | 3 |
| Rated current Signal contacts | 10 A |

| | |
|--|-------------------|
| Rated voltage | |
| acc. to UL/CSA | 600 V |
| Material | zinc die-cast |
| Limiting temperatures | -40 °C ... 125 °C |
| Flammability acc. to UL 94 | V 0 |
| Degree of protection acc. to EN 60 529 | IP 65 |

Hoods/housings Han-Compact®

| | |
|--|------------------------|
| Material | zinc die-cast |
| Surface | powder-coated RAL 9005 |
| Hoods/Housings sealing | NBR |
| Limiting temperatures | -40 °C ... 125 °C |
| Degree of protection acc. to EN 60 529 | IP 65 |
| for coupled connector | IP 65 |

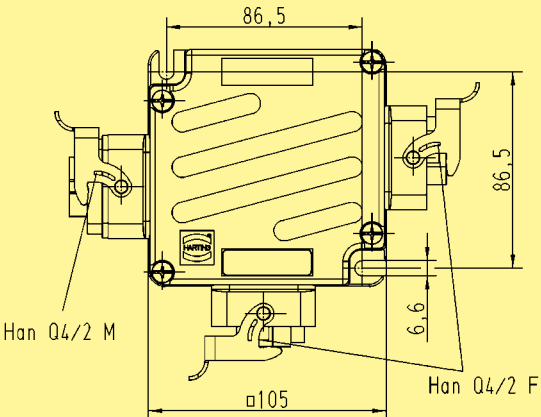

with 3x Han® Q 4/2

| Identification | Part number | Drawing | Dimensions in mm |
|---|------------------------------|---|------------------|
| <p>Han-Power® T Power supply with 3x Han® Q 4/2 in Han-Compact® Housings, bulkhead mounting</p> <p>4 mm²</p>  | <p>09 12 008 4720</p> |  | |

Features

- Per 1 connection for power input, power output and to device
- 4 power contacts
- Plastic housings are integrated in the moulding
- Compact design

Derating diagram

The power rating of the connectors is limited by the thermal load capability of the contact element material including the connections and the insulating parts. The derating curve is therefore valid for currents which flow constantly (non-intermittent) through each contact element of the connector evenly, without exceeding the allowed maximum temperature.

Measuring and testing techniques according to DIN EN 60 512-5

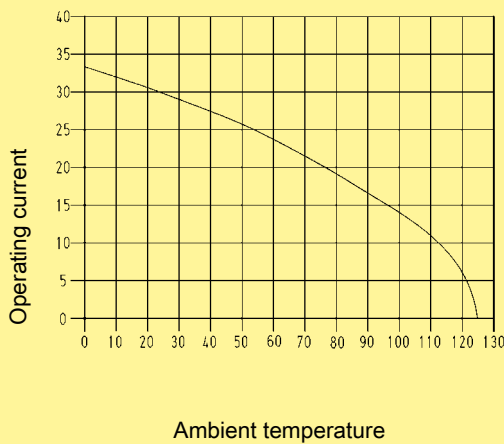

Wire gauge: 2.5 mm²

Technical characteristics

| | |
|----------------|-------------------------------|
| Specifications | DIN EN 61 984 DIN VDE 0110 |
|----------------|-------------------------------|

Han-Power® T

| | | | |
|--|------------------------------|------------------|---------------|
| Number of contacts | | | |
| - Power contacts | 5 + PE / ≤ 4 mm ² | | |
| Electrical data | | | |
| acc. to EN 61 984 | 16 A | 230/400 V | 4 kV 3 |
| Rated current | 16 A | | |
| Rated voltage conductor - ground | 230 V | | |
| Rated voltage conductor - conductor | 400 V | | |
| Rated impulse voltage | 4 kV | | |
| Pollution degree | 3 | | |
| Rated voltage | | | |
| acc. to UL/CSA | 600 V | | |
| Material | Polycarbonate | | |
| Limiting temperatures | -40 °C ... 125 °C | | |
| Flammability acc. to UL 94 | V 0 | | |
| Degree of protection acc. to EN 60 529 | IP 65 / IP 67 | | |

Hoods/housings Han A®

| | |
|--|-------------------|
| Material | Polycarbonate |
| Surface | RAL 9005 |
| Hoods/Housings sealing | NBR |
| Limiting temperatures | -40 °C ... 125 °C |
| Degree of protection acc. to EN 60 529 | IP 67 |
| for coupled connector | IP 67 |



with 3x Han® Q 5/0

Identification

Part number

Drawing

Dimensions in mm

Han-Power® T
 Power supply
 with 3x Han® Q 5/0
 in Han A®
 Housings, bulkhead mounting

2,5 mm²

09 12 008 4751

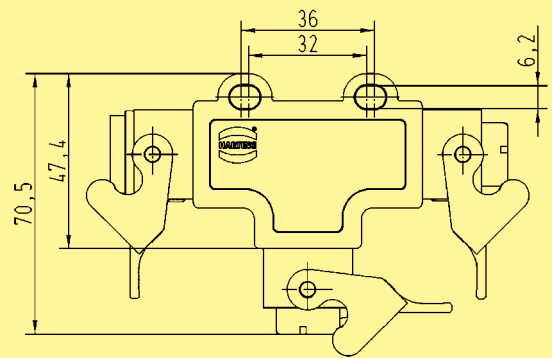

Features

- 4 power contacts Han® C and 2 signal contacts Han D®
- Finger protection
- Leading protective ground with crimp terminal
- Inserts suitable for metal and plastic hoods and housings of Han-Compact® series (not suitable for 19 12 008 0501)
- Coding possibilities by using a coding pin instead of fixing screw

Derating diagram

The power rating of the connectors is limited by the thermal load capability of the contact element material including the connections and the insulating parts. The derating curve is therefore valid for currents which flow constantly (non-intermittent) through each contact element of the connector evenly, without exceeding the allowed maximum temperature.

Measuring and testing techniques according to DIN EN 60 512-5

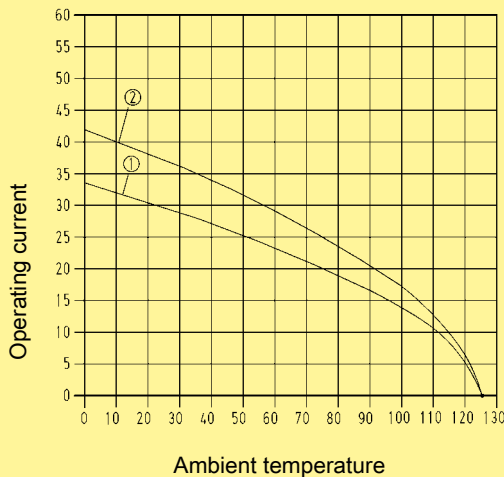

Wire gauge: ① 2.5 mm²
 ② 4 mm²

Technical characteristics

Specifications DIN EN 61 984
 DIN VDE 0110

Approvals us

Inserts

| | |
|-------------------------------------|------------------------------|
| Number of contacts | 4 + PE |
| Electrical data | |
| acc. to EN 61 984 | |
| Power side | 40 A 400/690 V 6 kV 3 |
| Rated current | 40 A |
| Rated voltage conductor - ground | 400 V |
| Rated voltage conductor - conductor | 690 V |
| Rated impulse voltage | 6 kV |
| Pollution degree | 3 |
| Signal side | 10 A 250 V 4 kV 3 |
| Rated current | 10 A |
| Rated voltage | 250 V |
| Rated impulse voltage | 4 kV |
| Pollution degree | 3 |

| | |
|----------------------------|----------------------|
| Rated voltage | |
| acc. to UL/CSA | 600 / 250 V |
| Insulation resistance | ≥ 10 ¹⁰ Ω |
| Material | Polycarbonate |
| Limiting temperatures | -40 °C ... 125 °C |
| Flammability acc. to UL 94 | V 0 |
| Mechanical working life | |
| - mating cycles | ≥ 500 |

Contacts

| | |
|--------------------------|---|
| Material | copper alloy |
| Surface | |
| - hard-silver plated | 3 μm Ag |
| - hard-gold plated | 2 μm Au over 3 μm Ni |
| Contact resistance | ≤ 0.3 mΩ |
| Crimp terminal | |
| - mm ² | 1.5 ... 6 mm ² / 0.14 ... 2.5 mm ² |
| - AWG | 16 ... 10 / 26 ... 14 |
| Max. insulation diameter | |
| - Power contacts | 5 mm |

Plastic hoods/housings

| | |
|--|-------------------|
| Material | Polycarbonate |
| Locking element | Polyamide |
| Flammability acc. to UL 94 | V 0 |
| Hoods/Housings sealing | NBR |
| Limiting temperatures | -40 °C ... 125 °C |
| Degree of protection acc. to EN 60 529 | IP 65 |
| for coupled connector | |

Accessories



| | |
|----------------|------------|
| Crimping tools | chapter 99 |
|----------------|------------|

Number of contacts

4/2 + 

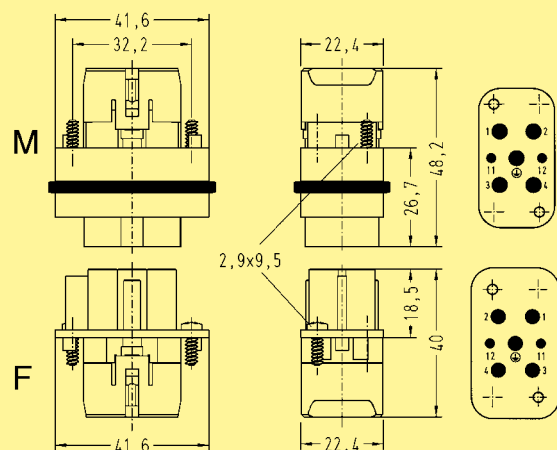
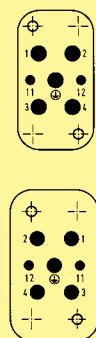

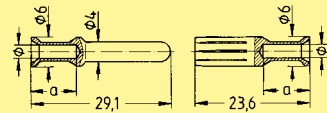
| Identification | Part number | | Drawing | Dimensions in mm |
|---|-----------------------|-----------------------|---|--|
| | Male insert (M) | Female insert (F) | | |
| Crimp terminal Order crimp contacts separately | 09 12 006 3041 | 09 12 006 3141 |  <p> M F Contact arrangement View from termination side </p> |  |

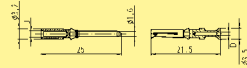
| Identification | Wire gauge (mm²) | Part number | | Drawing | Dimensions in mm | | | | | | | | | | | | | | | | | | | | | | | | | | | | | | | | | | | |
|--|---|--|--|---|--|------------|--|--|---|------------------|-----------|-----|-----------|------|------|-----|-----|--------|------|------|------|-----|--------|------|--------|---|-----|--------|------|--------|-----|-----|--------|------|------|-----|-----|--------|------|------|
| | | Male contact | Female contact | | | | | | | | | | | | | | | | | | | | | | | | | | | | | | | | | | | | | |
| Crimp contacts Han® C contacts Power contacts silver plated  | 1.5 2.5 4 6 | 09 32 000 6104 09 32 000 6105 09 32 000 6107 09 32 000 6108 | 09 32 000 6204 09 32 000 6205 09 32 000 6207 09 32 000 6208 |  | <table border="1"> <thead> <tr> <th colspan="3">Wire gauge</th> <th>∅</th> <th>Stripping length</th> </tr> </thead> <tbody> <tr> <td>1.5</td> <td>mm²</td> <td>AWG 16</td> <td>1.75</td> <td>9 mm</td> </tr> <tr> <td>2.5</td> <td>mm²</td> <td>AWG 14</td> <td>2.25</td> <td>9 mm</td> </tr> <tr> <td>4</td> <td>mm²</td> <td>AWG 12</td> <td>2.85</td> <td>9.6 mm</td> </tr> <tr> <td>6</td> <td>mm²</td> <td>AWG 10</td> <td>3.5</td> <td>9.6 mm</td> </tr> </tbody> </table> | Wire gauge | | | ∅ | Stripping length | 1.5 | mm² | AWG 16 | 1.75 | 9 mm | 2.5 | mm² | AWG 14 | 2.25 | 9 mm | 4 | mm² | AWG 12 | 2.85 | 9.6 mm | 6 | mm² | AWG 10 | 3.5 | 9.6 mm | | | | | | | | | | |
| Wire gauge | | | ∅ | Stripping length | | | | | | | | | | | | | | | | | | | | | | | | | | | | | | | | | | | | |
| 1.5 | mm² | AWG 16 | 1.75 | 9 mm | | | | | | | | | | | | | | | | | | | | | | | | | | | | | | | | | | | | |
| 2.5 | mm² | AWG 14 | 2.25 | 9 mm | | | | | | | | | | | | | | | | | | | | | | | | | | | | | | | | | | | | |
| 4 | mm² | AWG 12 | 2.85 | 9.6 mm | | | | | | | | | | | | | | | | | | | | | | | | | | | | | | | | | | | | |
| 6 | mm² | AWG 10 | 3.5 | 9.6 mm | | | | | | | | | | | | | | | | | | | | | | | | | | | | | | | | | | | | |
| Han D® contacts Signal contacts silver plated  gold plated  | 0.14-0.37 0.5 0.75 1 1.5 2.5 | 09 15 000 6104 09 15 000 6103 09 15 000 6105 09 15 000 6102 09 15 000 6101 09 15 000 6106 | 09 15 000 6204 09 15 000 6203 09 15 000 6205 09 15 000 6202 09 15 000 6201 09 15 000 6206 |  | <table border="1"> <thead> <tr> <th colspan="3">Wire gauge</th> <th>∅</th> <th>Stripping length</th> </tr> </thead> <tbody> <tr> <td>0.14-0.37</td> <td>mm²</td> <td>AWG 26-22</td> <td>0.9</td> <td>8 mm</td> </tr> <tr> <td>0.5</td> <td>mm²</td> <td>AWG 20</td> <td>1.1</td> <td>8 mm</td> </tr> <tr> <td>0.75</td> <td>mm²</td> <td>AWG 18</td> <td>1.3</td> <td>8 mm</td> </tr> <tr> <td>1</td> <td>mm²</td> <td>AWG 18</td> <td>1.45</td> <td>8 mm</td> </tr> <tr> <td>1.5</td> <td>mm²</td> <td>AWG 16</td> <td>1.75</td> <td>8 mm</td> </tr> <tr> <td>2.5</td> <td>mm²</td> <td>AWG 14</td> <td>2.25</td> <td>6 mm</td> </tr> </tbody> </table> | Wire gauge | | | ∅ | Stripping length | 0.14-0.37 | mm² | AWG 26-22 | 0.9 | 8 mm | 0.5 | mm² | AWG 20 | 1.1 | 8 mm | 0.75 | mm² | AWG 18 | 1.3 | 8 mm | 1 | mm² | AWG 18 | 1.45 | 8 mm | 1.5 | mm² | AWG 16 | 1.75 | 8 mm | 2.5 | mm² | AWG 14 | 2.25 | 6 mm |
| Wire gauge | | | ∅ | Stripping length | | | | | | | | | | | | | | | | | | | | | | | | | | | | | | | | | | | | |
| 0.14-0.37 | mm² | AWG 26-22 | 0.9 | 8 mm | | | | | | | | | | | | | | | | | | | | | | | | | | | | | | | | | | | | |
| 0.5 | mm² | AWG 20 | 1.1 | 8 mm | | | | | | | | | | | | | | | | | | | | | | | | | | | | | | | | | | | | |
| 0.75 | mm² | AWG 18 | 1.3 | 8 mm | | | | | | | | | | | | | | | | | | | | | | | | | | | | | | | | | | | | |
| 1 | mm² | AWG 18 | 1.45 | 8 mm | | | | | | | | | | | | | | | | | | | | | | | | | | | | | | | | | | | | |
| 1.5 | mm² | AWG 16 | 1.75 | 8 mm | | | | | | | | | | | | | | | | | | | | | | | | | | | | | | | | | | | | |
| 2.5 | mm² | AWG 14 | 2.25 | 6 mm | | | | | | | | | | | | | | | | | | | | | | | | | | | | | | | | | | | | |

Features

- 8 contact chambers for crimp contacts of Han E® series
- Space-saving and compact design
- Leading protective ground with crimp terminal
- Inserts suitable for metal and plastic hoods and housings of Han-Compact® series
- ISO 23 570 / DESINA conform product



Derating diagram

The power rating of the connectors is limited by the thermal load capability of the contact element material including the connections and the insulating parts. The derating curve is therefore valid for currents which flow constantly (non-intermittent) through each contact element of the connector evenly, without exceeding the allowed maximum temperature.

Measuring and testing techniques according to DIN EN 60 512-5

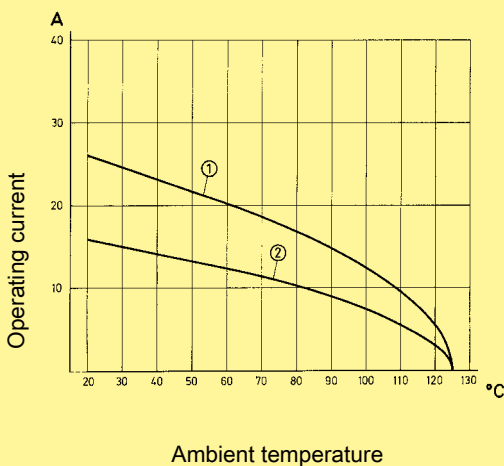

Wire gauge: ① 2.5 mm²
 ② 1.5 mm²

Technical characteristics

Specifications DIN EN 61 984
 DIN VDE 0110

Approvals

Inserts

| | |
|----------------------------|--------------------------|
| Number of contacts | 8 + PE |
| Electrical data | |
| acc. to EN 61 984 | |
| Mounted plastic hood | 16 A 500 V 6 kV 3 |
| Rated current | 16 A |
| Rated voltage | 500 V |
| Rated impulse voltage | 6 kV |
| Pollution degree | 3 |
| Pollution degree 2 also | 16 A 400/690 V 6 kV 2 |
| Mounted metal hood | 16 A 230/400 V 4 kV 3 |
| Rated voltage | |
| acc. to UL/CSA | 500 V |
| Insulation resistance | ≥ 10 ¹⁰ Ω |
| Material | Polycarbonate |
| Limiting temperatures | -40 °C ... 125 °C |
| Flammability acc. to UL 94 | V 0 |
| Mechanical working life | |
| - mating cycles | ≥ 500 |

Contacts

| | |
|----------------------|--|
| Material | copper alloy |
| Surface | |
| - hard-silver plated | 3 μm Ag |
| - hard-gold plated | 2 μm Au over 3 μm Ni |
| Contact resistance | ≤ 1 mΩ |
| Crimp terminal | |
| - mm ² | 0.14 ... 4 mm ² partly loaded up to 4 mm ² is possible |
| - AWG | 26 ... 12 |

Plastic hoods/housings

| | |
|--|-------------------|
| Material | Polycarbonate |
| Locking element | Polyamide |
| Flammability acc. to UL 94 | V 0 |
| Hoods/Housings sealing | NBR |
| Limiting temperatures | -40 °C ... 125 °C |
| Degree of protection acc. to EN 60 529 | IP 65 |
| for coupled connector | |

Hoods/Housings, metal

| | |
|--|-------------------|
| Material | zinc die-cast |
| Locking element | V2A steel |
| Hoods/Housings sealing | NBR |
| Limiting temperatures | -40 °C ... 125 °C |
| Degree of protection acc. to EN 60 529 | IP 65 |
| for coupled connector | |

Accessories

| | |
|----------------|------------|
| Crimping tools | chapter 99 |
|----------------|------------|

Number of contacts

8 +



| Identification | Part number | | Drawing | Dimensions in mm |
|---|-----------------------|-----------------------|---|---|
| | Male insert (M) | Female insert (F) | | |
| Crimp terminal Order crimp contacts separately | 09 12 008 3001 | 09 12 008 3101 | <p>Contact arrangement View from termination side</p> | |
| Coding pin | 09 33 000 9954 | 09 33 000 9954 | | Use of the coding pin prevents incorrect mating to other connectors of the same type. The male pin should be omitted from the opposing cavity in the male insert. |

| Identification | Wire gauge (mm²) | Part number | | Drawing | Dimensions in mm | | | | | | | | | | | | | | | | | | | | | | | | | | | | | | | | |
|---|------------------|----------------|------------------|---------|---|----------------|------------|--|------------------|-----------|---------------|-----------|--------|-----------|---------|--------|--------|-----------|----------|--------|--------|---------|-------|--------|--------|-----------|---------|--------|--------|-----------|---------|--------|--------|-----------|-------|--------|--------|
| | | Male contact | Female contact | | | | | | | | | | | | | | | | | | | | | | | | | | | | | | | | | | |
| Crimp contacts Power contacts silver plated | 0.14-0.37 | 09 33 000 6127 | 09 33 000 6227 | | <table border="1"> <thead> <tr> <th>Identification</th> <th colspan="2">Wire gauge</th> <th>Stripping length</th> </tr> </thead> <tbody> <tr> <td>no groove</td> <td>0.14-0.37 mm²</td> <td>AWG 26-22</td> <td>7.5 mm</td> </tr> <tr> <td>no groove</td> <td>0.5 mm²</td> <td>AWG 20</td> <td>7.5 mm</td> </tr> <tr> <td>1 groove*</td> <td>0.75 mm²</td> <td>AWG 18</td> <td>7.5 mm</td> </tr> <tr> <td>1 Rille</td> <td>1 mm²</td> <td>AWG 18</td> <td>7.5 mm</td> </tr> <tr> <td>2 grooves</td> <td>1.5 mm²</td> <td>AWG 16</td> <td>7.5 mm</td> </tr> <tr> <td>3 grooves</td> <td>2.5 mm²</td> <td>AWG 14</td> <td>7.5 mm</td> </tr> <tr> <td>no groove</td> <td>4 mm²</td> <td>AWG 12</td> <td>7.5 mm</td> </tr> </tbody> </table> | Identification | Wire gauge | | Stripping length | no groove | 0.14-0.37 mm² | AWG 26-22 | 7.5 mm | no groove | 0.5 mm² | AWG 20 | 7.5 mm | 1 groove* | 0.75 mm² | AWG 18 | 7.5 mm | 1 Rille | 1 mm² | AWG 18 | 7.5 mm | 2 grooves | 1.5 mm² | AWG 16 | 7.5 mm | 3 grooves | 2.5 mm² | AWG 14 | 7.5 mm | no groove | 4 mm² | AWG 12 | 7.5 mm |
| Identification | Wire gauge | | Stripping length | | | | | | | | | | | | | | | | | | | | | | | | | | | | | | | | | | |
| no groove | 0.14-0.37 mm² | AWG 26-22 | 7.5 mm | | | | | | | | | | | | | | | | | | | | | | | | | | | | | | | | | | |
| no groove | 0.5 mm² | AWG 20 | 7.5 mm | | | | | | | | | | | | | | | | | | | | | | | | | | | | | | | | | | |
| 1 groove* | 0.75 mm² | AWG 18 | 7.5 mm | | | | | | | | | | | | | | | | | | | | | | | | | | | | | | | | | | |
| 1 Rille | 1 mm² | AWG 18 | 7.5 mm | | | | | | | | | | | | | | | | | | | | | | | | | | | | | | | | | | |
| 2 grooves | 1.5 mm² | AWG 16 | 7.5 mm | | | | | | | | | | | | | | | | | | | | | | | | | | | | | | | | | | |
| 3 grooves | 2.5 mm² | AWG 14 | 7.5 mm | | | | | | | | | | | | | | | | | | | | | | | | | | | | | | | | | | |
| no groove | 4 mm² | AWG 12 | 7.5 mm | | | | | | | | | | | | | | | | | | | | | | | | | | | | | | | | | | |
| gold plated | 0.14-0.37 | 09 33 000 6117 | 09 33 000 6217 | | | | | | | | | | | | | | | | | | | | | | | | | | | | | | | | | | |
| Relay contact silver plated | 0.75-1 | 09 33 000 6109 | | | | | | | | | | | | | | | | | | | | | | | | | | | | | | | | | | | |
| | 1.5 | 09 33 000 6110 | | | | | | | | | | | | | | | | | | | | | | | | | | | | | | | | | | | |
| | 2.5 | 09 33 000 6111 | | | | | | | | | | | | | | | | | | | | | | | | | | | | | | | | | | | |
| F.O. contacts for 1 mm plastic fibre | | 20 10 001 3311 | 20 10 001 3321 | | | | | | | | | | | | | | | | | | | | | | | | | | | | | | | | | | |

Crimp contacts 0.14 ... 0.37 mm² only used with BUCHANAN crimping tool 09 99 000 0001 and adjustment gauge 09 99 000 0203

Features

- 5 contact chambers for crimp contacts of Han E® series
- Space-saving and compact design
- Leading protective ground with screw terminal
- Compatible with plastic and metal hoods of series Han® 3 A

Derating diagram

The power rating of the connectors is limited by the thermal load capability of the contact element material including the connections and the insulating parts. The derating curve is therefore valid for currents which flow constantly (non-intermittent) through each contact element of the connector evenly, without exceeding the allowed maximum temperature.

Measuring and testing techniques according to DIN EN 60 512-5

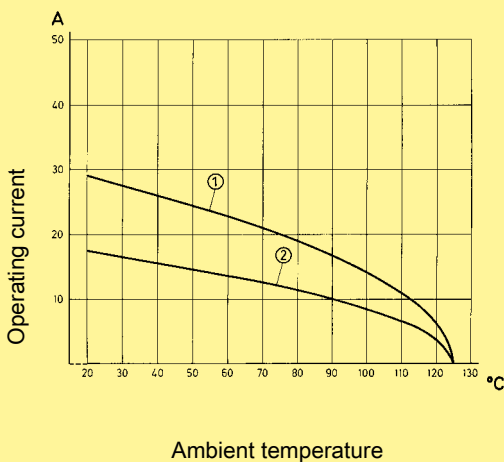

- Wire gauge: ① 2.5 mm²
 ② 1.5 mm²

Technical characteristics

Specifications DIN EN 61 984
 DIN VDE 0110

Approvals

Inserts

Number of contacts 5 + PE
 Electrical data
 acc. to EN 61 984 **16 A 230/400 V 4 kV 3**
 Rated current 16 A
 Rated voltage conductor - ground 230 V
 Rated voltage conductor - conductor 400 V
 Rated impulse voltage 4 kV
 Pollution degree 3
 Pollution degree 2 also 16 A 320/500 V 4 kV 2
 Rated voltage
 acc. to UL/CSA 600 V
 Insulation resistance ≥ 10¹⁰ Ω
 Material Polycarbonate
 Limiting temperatures -40 °C ... 125 °C
 Flammability acc. to UL 94 V 0
 Mechanical working life
 - mating cycles ≥ 500

Contacts

Material copper alloy
 Surface
 - hard-silver plated 3 µm Ag
 - hard-gold plated 2 µm Au over 3 µm Ni
 Contact resistance ≤ 1 mΩ
 Crimp terminal
 - mm² 0.14 ... 2.5 mm²
 - AWG 26 ... 14

Plastic hoods/housings

Material Polycarbonate
 Locking element Polyamide
 Flammability acc. to UL 94 V 0
 Hoods/Housings sealing NBR
 Limiting temperatures -40 °C ... 125 °C
 Degree of protection acc. to EN 60 529
 for coupled connector IP 67

Hoods/Housings, metal

Material zinc die-cast
 Locking element steel, zinc-plated
 Hoods/Housings sealing NBR
 Limiting temperatures -40 °C ... 125 °C
 Degree of protection acc. to EN 60 529
 for coupled connector IP 44 /
 IP 67 is achieved with seal
 screw 09 20 000 9918

Accessories

Crimping tools chapter 99
 Cable clamps chapter 40
 Sealing screw chapter 40

Number of contacts

5 +







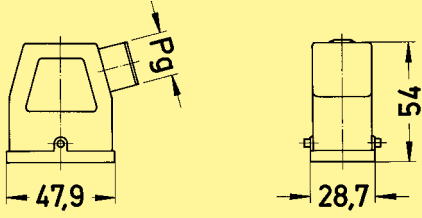

| Identification | Part number | | Drawing | Dimensions in mm |
|--|-----------------------|-----------------------|---|---|
| | Male insert (M) | Female insert (F) | | |
| Crimp terminal Order crimp contacts separately | 09 12 005 3001 | 09 12 005 3101 | <p>Contact arrangement View from termination side</p> | |
| Coding pin | 09 33 000 9954 | 09 33 000 9954 | | Use of the coding pin prevents incorrect mating to other connectors of the same type. The male pin should be omitted from the opposing cavity in the male insert. |

| Identification | Wire gauge (mm ²) | Part number | | Drawing | Dimensions in mm | | | | | | | | | | | | | | | | | | | | | | | | | | | | | | |
|--|-------------------------------|-----------------------|-----------------------|--|------------------|------------|--|------------------|-----------|---------------------------|-----------|--------|-----------|---------------------|--------|--------|-----------|----------------------|--------|--------|---------|-------------------|--------|--------|-----------|---------------------|--------|--------|-----------|---------------------|--------|--------|--|--|--|
| | | Male contact | Female contact | | | | | | | | | | | | | | | | | | | | | | | | | | | | | | | | |
| Crimp contacts Power contacts silver plated | 0.14-0.37 | 09 33 000 6127 | 09 33 000 6227 | <table border="1"> <thead> <tr> <th>Identification</th> <th colspan="2">Wire gauge</th> <th>Stripping length</th> </tr> </thead> <tbody> <tr> <td>no groove</td> <td>0.14-0.37 mm²</td> <td>AWG 26-22</td> <td>7.5 mm</td> </tr> <tr> <td>no groove</td> <td>0.5 mm²</td> <td>AWG 20</td> <td>7.5 mm</td> </tr> <tr> <td>1 groove*</td> <td>0.75 mm²</td> <td>AWG 18</td> <td>7.5 mm</td> </tr> <tr> <td>1 Rille</td> <td>1 mm²</td> <td>AWG 18</td> <td>7.5 mm</td> </tr> <tr> <td>2 grooves</td> <td>1.5 mm²</td> <td>AWG 16</td> <td>7.5 mm</td> </tr> <tr> <td>3 grooves</td> <td>2.5 mm²</td> <td>AWG 14</td> <td>7.5 mm</td> </tr> </tbody> </table> <p>* on the back crimp collar</p> | Identification | Wire gauge | | Stripping length | no groove | 0.14-0.37 mm ² | AWG 26-22 | 7.5 mm | no groove | 0.5 mm ² | AWG 20 | 7.5 mm | 1 groove* | 0.75 mm ² | AWG 18 | 7.5 mm | 1 Rille | 1 mm ² | AWG 18 | 7.5 mm | 2 grooves | 1.5 mm ² | AWG 16 | 7.5 mm | 3 grooves | 2.5 mm ² | AWG 14 | 7.5 mm | | | |
| Identification | Wire gauge | | Stripping length | | | | | | | | | | | | | | | | | | | | | | | | | | | | | | | | |
| no groove | 0.14-0.37 mm ² | AWG 26-22 | 7.5 mm | | | | | | | | | | | | | | | | | | | | | | | | | | | | | | | | |
| no groove | 0.5 mm ² | AWG 20 | 7.5 mm | | | | | | | | | | | | | | | | | | | | | | | | | | | | | | | | |
| 1 groove* | 0.75 mm ² | AWG 18 | 7.5 mm | | | | | | | | | | | | | | | | | | | | | | | | | | | | | | | | |
| 1 Rille | 1 mm ² | AWG 18 | 7.5 mm | | | | | | | | | | | | | | | | | | | | | | | | | | | | | | | | |
| 2 grooves | 1.5 mm ² | AWG 16 | 7.5 mm | | | | | | | | | | | | | | | | | | | | | | | | | | | | | | | | |
| 3 grooves | 2.5 mm ² | AWG 14 | 7.5 mm | | | | | | | | | | | | | | | | | | | | | | | | | | | | | | | | |
| gold plated | 0.14-0.37 | 09 33 000 6117 | 09 33 000 6217 | | | | | | | | | | | | | | | | | | | | | | | | | | | | | | | | |
| | 0.5 | 09 33 000 6122 | 09 33 000 6222 | | | | | | | | | | | | | | | | | | | | | | | | | | | | | | | | |
| | 0.75 | 09 33 000 6115 | 09 33 000 6215 | | | | | | | | | | | | | | | | | | | | | | | | | | | | | | | | |
| | 1 | 09 33 000 6118 | 09 33 000 6218 | | | | | | | | | | | | | | | | | | | | | | | | | | | | | | | | |
| | 1.5 | 09 33 000 6116 | 09 33 000 6216 | | | | | | | | | | | | | | | | | | | | | | | | | | | | | | | | |
| | 2.5 | 09 33 000 6123 | 09 33 000 6223 | | | | | | | | | | | | | | | | | | | | | | | | | | | | | | | | |
| Relay contact silver plated | 0.75-1 | 09 33 000 6109 | | | | | | | | | | | | | | | | | | | | | | | | | | | | | | | | | |
| | 1.5 | 09 33 000 6110 | | | | | | | | | | | | | | | | | | | | | | | | | | | | | | | | | |
| | 2.5 | 09 33 000 6111 | | | | | | | | | | | | | | | | | | | | | | | | | | | | | | | | | |
| F.O. contacts for 1 mm plastic fibre | | 20 10 001 3311 | 20 10 001 3321 | | | | | | | | | | | | | | | | | | | | | | | | | | | | | | | | |

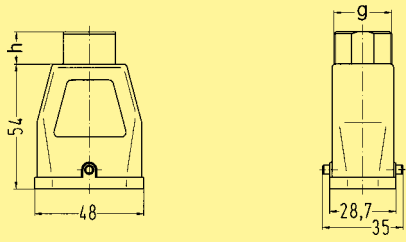
Crimp contacts 0.14 ... 0.37 mm² only used with BUCHANAN crimping tool 09 99 000 0001 and adjustment gauge 09 99 000 0203

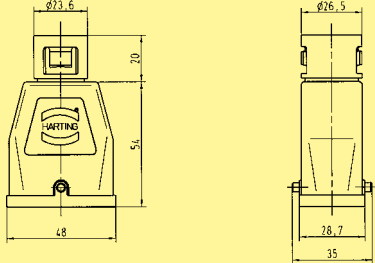
thermoplastic / metal

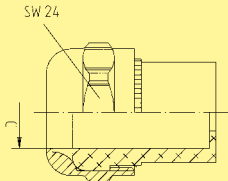





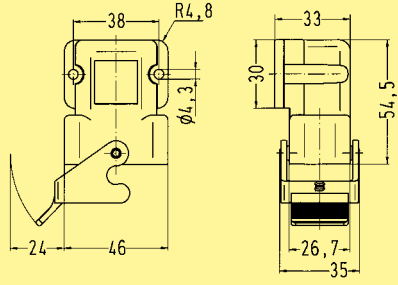

| Identification | Part number | Drawing | Dimensions in mm | | | | | | | | | | | | | | | | | | | | |
|---|---|---|--|---|-------|----|----------|------|----------------|---------|---------|----------------|---------|-------|----------------|-------|-------|----------------|-------|-------|----------------|-------|---------|
| <p>Hoods</p> <p>Hoods</p> <p>Thermoplastic side-entry Cable gland order separately</p>  | 09 12 008 0527 | Pg 16 |  | | | | | | | | | | | | | | | | | | | | |
| <p>Hoods</p> <p>Thermoplastic top-entry Cable gland order separately</p>  | 19 12 008 0429 09 12 008 0427 09 12 008 0429 | M 25 Pg 16 Pg 21 |  <table border="1" data-bbox="976 999 1161 1122"> <thead> <tr> <th>h</th> <th>g</th> </tr> </thead> <tbody> <tr> <td>14</td> <td>M 25x1.5</td> </tr> <tr> <td>13</td> <td>Pg 16</td> </tr> <tr> <td>13</td> <td>Pg 21</td> </tr> </tbody> </table> | h | g | 14 | M 25x1.5 | 13 | Pg 16 | 13 | Pg 21 | | | | | | | | | | | | |
| h | g | | | | | | | | | | | | | | | | | | | | | | |
| 14 | M 25x1.5 | | | | | | | | | | | | | | | | | | | | | | |
| 13 | Pg 16 | | | | | | | | | | | | | | | | | | | | | | |
| 13 | Pg 21 | | | | | | | | | | | | | | | | | | | | | | |
| <p>Hoods</p> <p>Thermoplastic top-entry Cable gland order separately</p>  | 09 12 008 0428 | Pg 16 |  | | | | | | | | | | | | | | | | | | | | |
| <p>Cable seal</p> <p>Thermoplastic for hoods Thrust bolt and insert</p>  | 09 00 000 5059 19 12 000 5157 19 12 000 5158 09 00 000 5157 09 00 000 5158 | Pg 16 M 25 M 25 Pg 21 Pg 21 |  <table border="1" data-bbox="976 1653 1369 1865"> <thead> <tr> <th rowspan="2"></th> <th colspan="2">cable</th> </tr> <tr> <th>min.</th> <th>max.</th> </tr> </thead> <tbody> <tr> <td>09 00 000 5059</td> <td>11.5 mm</td> <td>15.5 mm</td> </tr> <tr> <td>19 12 000 5157</td> <td>10.5 mm</td> <td>14 mm</td> </tr> <tr> <td>19 12 000 5158</td> <td>14 mm</td> <td>17 mm</td> </tr> <tr> <td>09 00 000 5157</td> <td>14 mm</td> <td>18 mm</td> </tr> <tr> <td>09 00 000 5158</td> <td>17 mm</td> <td>20.5 mm</td> </tr> </tbody> </table> | | cable | | min. | max. | 09 00 000 5059 | 11.5 mm | 15.5 mm | 19 12 000 5157 | 10.5 mm | 14 mm | 19 12 000 5158 | 14 mm | 17 mm | 09 00 000 5157 | 14 mm | 18 mm | 09 00 000 5158 | 17 mm | 20.5 mm |
| | cable | | | | | | | | | | | | | | | | | | | | | | |
| | min. | max. | | | | | | | | | | | | | | | | | | | | | |
| 09 00 000 5059 | 11.5 mm | 15.5 mm | | | | | | | | | | | | | | | | | | | | | |
| 19 12 000 5157 | 10.5 mm | 14 mm | | | | | | | | | | | | | | | | | | | | | |
| 19 12 000 5158 | 14 mm | 17 mm | | | | | | | | | | | | | | | | | | | | | |
| 09 00 000 5157 | 14 mm | 18 mm | | | | | | | | | | | | | | | | | | | | | |
| 09 00 000 5158 | 17 mm | 20.5 mm | | | | | | | | | | | | | | | | | | | | | |

thermoplastic / metal

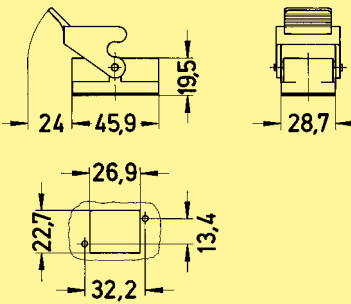

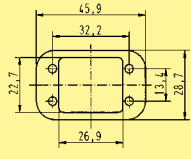
| Identification | Part number | Drawing | Dimensions in mm | | | | | | | | | | | |
|---|---|--|------------------|-------|--|------|------|-----------------------|---------|-------|-----------------------|-------|-------|--|
| Hoods Hoods Metal side-entry Cable gland order separately | 19 12 008 0526 | | | | | | | | | | | | | |
| Hoods Metal side-entry Cable gland order separately | black chromated 19 12 008 0501 black powder coated 19 12 708 0501 matt nickel plated 19 12 008 0502 | | | | | | | | | | | | | |
| Hoods Metal top-entry Cable gland order separately | 19 12 008 0426 | | | | | | | | | | | | | |
| Cable seal Metal for hoods Thrust bolt and insert | 19 12 000 5057 19 12 000 5058 | <table border="1"> <thead> <tr> <th rowspan="2"></th> <th colspan="2">cable</th> </tr> <tr> <th>min.</th> <th>max.</th> </tr> </thead> <tbody> <tr> <td>19 12 000 5057</td> <td>10.5 mm</td> <td>14 mm</td> </tr> <tr> <td>19 12 000 5058</td> <td>14 mm</td> <td>17 mm</td> </tr> </tbody> </table> | | cable | | min. | max. | 19 12 000 5057 | 10.5 mm | 14 mm | 19 12 000 5058 | 14 mm | 17 mm | |
| | cable | | | | | | | | | | | | | |
| | min. | max. | | | | | | | | | | | | |
| 19 12 000 5057 | 10.5 mm | 14 mm | | | | | | | | | | | | |
| 19 12 000 5058 | 14 mm | 17 mm | | | | | | | | | | | | |

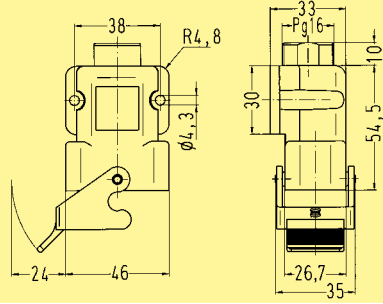
| Identification | Part number | | Drawing | Dimensions in mm |
|---|--|---------------------------------------|---------|------------------|
| | for male insert | for female insert | | |
| Protection covers Thermoplastic for male insert | without sealing 09 12 008 5407 | with sealing 09 12 008 5408 | | |

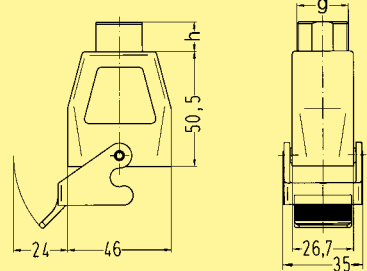
thermoplastic / metal

| Identification | Part number | Drawing | Dimensions in mm | | | | | | |
|---|--|---------------|--|---|---|----|-------|----|----------|
| <p>Housings</p> <p>Housings, bulkhead mounting</p> <p>Thermoplastic angled</p>  | 09 12 008 0902 | Pg 16 |  | | | | | | |
| <p>Housings, bulkhead mounting</p> <p>Thermoplastic</p>  | 09 12 008 0327 | Pg 16 |  | | | | | | |
| <p>Gasket for housings bulkhead mounting</p> <p>Han® Q 8/0</p>  | 09 12 000 9912 | |  | | | | | | |
| <p>Housings, surface mounting</p> <p>Thermoplastic angled</p> <p>Cable gland order separately</p>  | 09 12 008 0901 | Pg 16 |  | | | | | | |
| <p>Hoods, cable to cable</p> <p>Thermoplastic</p> <p>Cable gland order separately</p>  | 09 12 008 0727 19 12 008 0729 | Pg 16 M 25 |  <table border="1" data-bbox="973 1960 1165 2060"> <tr> <td>h</td> <td>g</td> </tr> <tr> <td>13</td> <td>Pg 16</td> </tr> <tr> <td>14</td> <td>M 25x1.5</td> </tr> </table> | h | g | 13 | Pg 16 | 14 | M 25x1.5 |
| h | g | | | | | | | | |
| 13 | Pg 16 | | | | | | | | |
| 14 | M 25x1.5 | | | | | | | | |

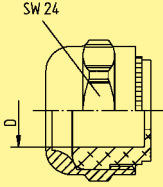
thermoplastic / metal

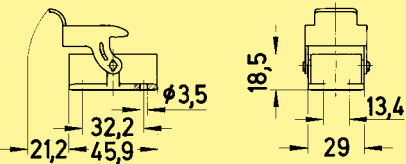
| Identification | Part number | Drawing | Dimensions in mm | | | | | | | | |
|--|---|--------------|---|----------------|-------|--|------|------|--|---------|---------|
| <p>Housings</p> <p>Cable seal</p> <p>Thermoplastic for housings Thrust bolt and insert</p>  | <p>09 00 000 5058</p> | <p>Pg 16</p> |  <table border="1" data-bbox="1010 566 1398 658"> <thead> <tr> <th rowspan="2">09 00 000 5058</th> <th colspan="2">cable</th> </tr> <tr> <th>min.</th> <th>max.</th> </tr> </thead> <tbody> <tr> <td></td> <td>11.5 mm</td> <td>15.5 mm</td> </tr> </tbody> </table> | 09 00 000 5058 | cable | | min. | max. | | 11.5 mm | 15.5 mm |
| 09 00 000 5058 | cable | | | | | | | | | | |
| | min. | max. | | | | | | | | | |
| | 11.5 mm | 15.5 mm | | | | | | | | | |
| <p>Housings, bulkhead mounting</p> <p>Metal</p>  | <p>black chromated 09 12 008 0301</p> <p>black powder coated 09 12 708 0301</p> <p>matt nickel plated 09 12 008 0303</p> | |  | | | | | | | | |

Identification

Part number

Drawing

Dimensions in mm

Panel feed through sealings

Cable diameter

7 - 10 mm²

10 - 13 mm²

13 - 16 mm²

16 - 19 mm²

19 - 22 mm²



blind grommet

09 12 000 9969

09 12 000 9970

09 12 000 9971

09 12 000 9972

09 12 000 9973

09 12 000 9974

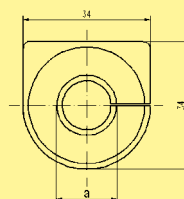

Production plants – worldwide



Sales Partner – worldwide



Espelkamp / Germany – Plant 1



Espelkamp / Germany – Plant 2



Espelkamp / Germany – Plant 3



Espelkamp / Germany – Plant 4



Espelkamp / Germany – Plant 5

Argentina

Condelectric S.A.
Hipólito Yrigoyen 2591
(B1640HFY) Martínez, Buenos Aires
Phone + Fax +54 11 4836-1053
E-Mail: info@condelectric.com.ar

Bulgaria

COMET ELECTRONICS
16, Tsar Samuil Str., BG-1000 Sofia
Phone +359-2-9155800
Fax +359-2-9540384
E-Mail: office@comet.bg
Internet: www.comet.bg

Denmark

Knud Wexøe A/S
Skaettekaeret 11, P.O. Box 152
DK-2840 Holte
Phone +4545465800
Fax +4545465801
E-Mail: wexoe@wexoe.dk
Internet: www.wexoe.dk



Zhuhai / China



Northampton / Great Britain



Sibiu / Romania

Estonia

SKS-tehnika Ou
Mustamäe tee 55, EE-10621 Tallinn
Phone +372 6819 234
Fax +372 6819 235
E-Mail: peeter.kuus@sksf.fi

Finland

SKS-automaatio OY
Martinkyläntie 50, FIN-01721 Vantaa
Phone +3589852661
Fax +35898526820
E-Mail: automaatio@sksf.fi

Hungary

Mile Kft., Mádi u. 52, H-1104 Budapest
Phone +36-1-431-9800
Fax +36-1-431-9817
E-Mail: milekft@mile-kft.hu
Internet: www.mile-kft.hu

Island

Smith & Norland, Nóatún 4
IS – 105 Reykjavík
Phone +354 520 3000
Fax +354 520 3011
E-Mail: olaf@sminor.is
Internet: www.sminor.is

Israel

MIGVAN
Technologies & Engineering Ltd.
13 Hashiloh St., P.O.Box 7022
IL – Petach Tikva 49170
Phone +972 3 9240784
Fax +972 3 9240787
E-Mail: info@mte.co.il
Internet: www.mte.co.il



Biel / Switzerland



Elgin / USA

Representatives – worldwide



Kanada

Chartwell Electronics Inc.
140 Duffield Drive
Markham, Ontario L6G 1B5
Phone 905-513-7100
Toll Free 877-513-7769
Fax 905-513-7101
Internet: www.chartwell.ca

Poland

Soyter Sp. z o. o., ul. Warszawska 3
05-082 Warszawa – Stare Babice
Phone +48 22 722 0 685
Fax +48 22 722 0 550
E-Mail: handlowy@soyter.com.pl
Internet: www.soyter.com

South Africa

HellermannTyton Pty Ltd.
Private Bag X158 Rivonia 2128
34 Milky Way Avenue
Linbro Business Park 2065
Johannesburg, South Africa
Phone +27(0)11879-6600
Fax +27(0)11879-6606
E-Mail: sales.jhb@hellermann.co.za

Turkey

Gökhan Elektrik San. Tic. Ltd. Sti.
Perpa Elektrikçiler Is Merkezi A Blok
Kat:7-8-9 No.694
TR – 80270 Okmeydani/Istanbul
Phone +90(212) 2213236 (pbx)
Fax +90(212) 2213240
E-Mail:
gokhan@gokhanelektrik.com.tr
Internet: www.gokhanelektrik.com

Ukraine

Incomtech Ltd.
4 Lermontovskaya St.
UA-04050 Kiev
Phone +380-44-213-3641
Fax +380-44-213-3814
E-Mail: eletech@incomtech.com.ua
Internet: www.incomtech.com.ua

Global Business Unit Electric



HARTING Electric GmbH & Co. KG

P.O. Box 14 73
D-32328 Espelkamp

Phone +49 57 72 / 47-97 100
Fax +49 57 72 / 47-4 95

E-Mail: electric@HARTING.com
Internet: www.HARTING.com

Distributor – Switzerland



Distrelec AG
Grabenstrasse 6
CH-8606 Nänikon
Telefon +41 1 944 99 11
Fax +41 1 944 99 88
E-Mail: info@distrelec.com
Internet: www.distrelec.com

Subsidiary companies – worldwide



Austria

HARTING Ges. m. b. H.
Deutschstraße 19, A-1230 Wien
Phone +431/6162121
Fax +431/6162121-21
E-Mail: at@HARTING.com

Belgium

HARTING N.V./S.A.
Z.3 Doornveld 23, B-1731 Zellik
Phone +322/4660190
Fax +322/4667855
E-Mail: be@HARTING.com

Brazil

HARTING Ltda.
Av. Dr. Lino de Moraes
Pq. Jabaquara, 255
CEP 04360-001 –
São Paulo – SP – Brazil
Phone +5511/5035-0073
Fax +5511/5034-4743
E-Mail: br@HARTING.com
Internet: www.HARTING.com.br

China

Zhuhai HARTING Limited
Shanghai branch
Room 5403, 300 Huaihai Zhong Road
Hong Kong New World Tower
Luwan District, P.R.C
Shanghai 200021, China
Phone +86 21 – 63 86 22 00
Fax +86 21 – 63 86 86 36
E-Mail: cn@HARTING.com

Czech Republic

HARTING spol. s.r.o.
Mlýnská 2, 16000 Praha 6
Phone +420 220 380 460
Fax +420 220 380 461
E-Mail: cz@HARTING.com
Internet: www.HARTING.cz

Finland

HARTING Oy
Teknobulevardi 3-5, PL 35
FI-01530 Vantaa
Phone +358 9 350 873 00
Fax +358 9 350 873 20
E-Mail: fi@HARTING.com

France

HARTING France
181 avenue des Nations
Paris Nord 2
BP 66058 Tremblay en France
F-95972 Roissy
Charles de Gaulle Cédex
Phone +33149383400
Fax +33148632306
E-Mail: fr@HARTING.com

Germany

HARTING Deutschland GmbH & Co. KG
Postfach 2451, D-32381 Minden
Simeonscarré 1, D-32427 Minden
Phone (0571) 8896-0
Fax (0571) 8896-282
E-Mail: de@HARTING.com
Internet: www.HARTING.com

Office Germany

HARTING Deutschland GmbH & Co. KG
Blankenauer Straße 99
D-09113 Chemnitz
Phone +49 0371 429211
Fax +49 0371 429222
E-Mail: de.sales@HARTING.com



Great Britain

HARTING Ltd., Caswell Road
Brackmills Industrial Estate
GB-Northampton, NN4 7PW
Phone +441604/766686, 827500
Fax +441604/706777
E-Mail: gb@HARTING.com
Internet: www.HARTING.co.uk

Hong Kong

HARTING (HK) Limited
Regional Office Asia Pacific
4208 Metroplaza Tower 1
223 Hing Fong Road
Kwai Fong, N. T., Hong Kong
Phone +852/2423-7338
Fax +852/2480-4378
E-Mail: ap@HARTING.com
Internet: www.HARTING.com.hk

Hungary

HARTING Eastern Europe GmbH
Magyarországi Kereskedelmi Képviselete
1119 Budapest, Fehérvári út 89-95.
II. emelet 217/A.
Phone +36-1-205 3464
Fax +36-1-205 3465
E-Mail: hu@HARTING.com
Internet: www.HARTING.hu

India

HARTING India Private Limited
No. D, 4th Floor, 'Doshi Towers'
No. 156 Poonamallee High Road,
Kilpauk, Chennai 600 010,
Tamil Nadu, Chennai
Phone +91-44-4356 0415/6
Fax +91-44-4356 0417
E-Mail: in@HARTING.com
Internet: www.HARTING.com

Italy

HARTING SpA
Via Dell' Industria 7
I-20090 Vimodrone (Milano)
Phone +3902/250801
Fax +3902/2650597
E-Mail: it@HARTING.com

Japan

HARTING K. K.
Yusen Shin-Yokohama 1 Chome Bldg.,
2F, 1-7-9, Shin-Yokohama
Kohoku-ku, Yokohama, 222-0033 Japan
Phone +81 45 476 3456
Fax +81 45 476 3466
E-Mail: jp@HARTING.com
Internet: www.HARTING.co.jp

Korea

HARTING Korea Limited
#308 Leaders Bldg., 342-1, Yatap-dong
Bundang-gu, Sungnam-City, Kyunggi-do
463-828, Korea
Phone +82-31-781-4615
Fax +82-31-781-4616
E-Mail: kr@HARTING.com

Netherlands

HARTING B.V.
Larenweg 44
NL-5234 KA 's-Hertogenbosch
Postbus 3526
NL-5203 DM 's-Hertogenbosch
Phone +3173/6410404
Fax +3173/6440699
E-Mail: nl@HARTING.com

Norway

HARTING A/S
Østensjøveien 36, N-0667 Oslo
Phone +4722/700555
Fax +4722/700570
E-Mail: no@HARTING.com

Poland

HARTING Eastern Europe GmbH
Przedstawicielstwo w Polsce
ul. Kamieńskiego 201-219
51-126 Wrocław
Phone +48 71-352 81 71
Phone +48 71-352 81 74
Fax +48 71-320 74 44
E-Mail: pl@HARTING.com
Internet: www.HARTING.pl

Portugal

HARTING Iberia, S. A.
Avda. Josep Tarradellas, 20-30, 4o 6a
E-08029 Barcelona
Phone +351.219.673.177
Fax +351.219.678.457
E-Mail: es@HARTING.com

Russia

HARTING ZAO, ul. Tobolskaja 12
Saint Petersburg, 194044 Russia
Phone +7/812/3276477
Fax +7/812/3276478
E-Mail: ru@HARTING.com
Internet: www.HARTING.ru

Singapore

HARTING Singapore Pte Ltd.
No. 1 Coleman Street
#B1-21 The Adelphi
Singapore 179803
Phone +6562255285, Fax +6562259947
E-Mail: sg@HARTING.com

Spain

HARTING Iberia S.A.
Josep Tarradellas 20-30 4o 6a
E-08029 Barcelona
Phone +34 933 638 475
Fax +34 934 199 585
E-Mail: es@HARTING.com

Sweden

HARTING AB
Gustavslundsvägen 141 B 4tr
167 51 Bromma
Phone +468/4457171
Fax +468/4457170
E-Mail: se@HARTING.com

Switzerland

HARTING AG
Industriestrasse 26
CH-8604 Volketswil
Phone +4144 9082060
Fax +4144 9082069
E-Mail: ch@HARTING.com

Taiwan

HARTING R.O.C. Limited
Room 1, 5th Floor,
No. 495 GuangFu South Road
Taiwan – Taipei 110
Phone +886 02-2758-6177
Fax +886 02-2758-7177
E-Mail: tw@HARTING.com
Internet: www.HARTING.com.tw

USA

HARTING Inc. of North America
1370 Bowes Road
Elgin, Illinois 60123
Phone +1 (877) 741-1500 (toll free)
Fax +1 (866) 278-0307 (Inside Sales)
Fax +1 (847) 717-9430 (Sales and Marketing)
E-Mail: us@HARTING.com
Internet: www.HARTING-USA.com

Eastern-Europe

HARTING Eastern Europe GmbH
Bamberger Straße 7, D-01187 Dresden
Phone +49 351 / 4361760
Fax +49 351 / 4361770
E-Mail: Eastern.Europe@HARTING.com

Distributors
– worldwide



Farnell InOne

www.farnellinone.com;
in US: Newark InOne:
www.newarkinone.com

RS Components

www.rs-components.com;
in US: Allied Electronics:
www.alliedelec.com

Other countries



HARTING Electric GmbH & Co. KG
P.O. Box 1473, D-32328 Espelkamp
Phone +495772/47-97100
Fax + 495772/47-495
E-Mail:
electric@HARTING.com



Pushing Performance

www.HARTING.com